

REV	ECN No.	DATE	REMARK
A	NEW	2021-02-02	NEW RELEASE

CAP 示意图

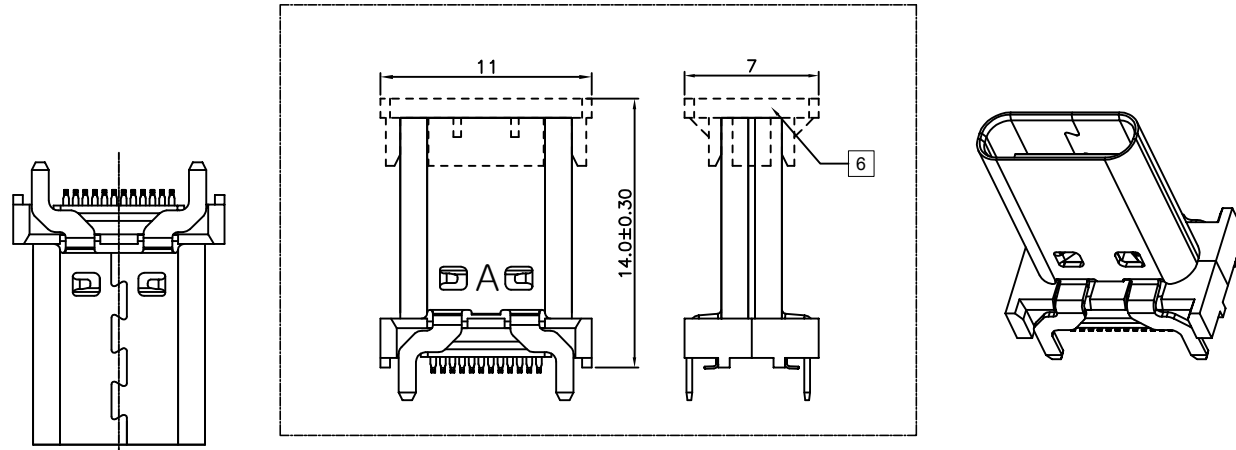

- NOTE:
- Contact Resistance: 40mOHM Max.;
 - Dielectric Withstanding Voltage: 100V AC For 1 Minute;
 - Insulation Resistance: 100M OHM Min.;
 - Mating And Unmating Force:
Mating Force: 5~20N
Unmating Force: 8~20N;
6~20N AFTER TEST;
 - Durability: 10000 Cycles;
 - PART NUMBER CODE:

CF251-24 L X XX R-C3

CONTACTS PLATED:
O1: 半金锡 1u"
HOUSING COLOR:
B: BLACK

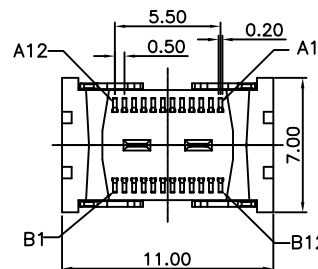
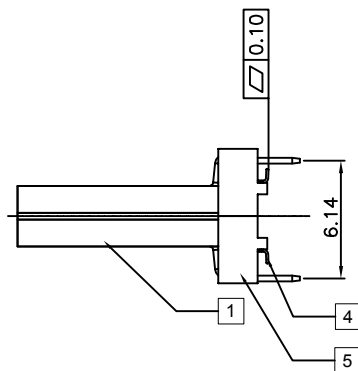
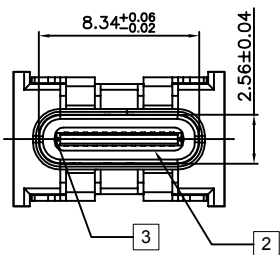

USB TYPE-C PIN ASSIGNMENTS

PIN NUMBER	SIGNAL NAME	PIN NUMBER	SIGNAL NAME
A1	GND	B12	GND
A2	SSTXp1	B11	SSRXp1
A3	SSTXn1	B10	SSRXn1
A4	Vbus	B9	Vbus
A5	CC1	B8	SBU2
A6	Dp1	B7	Dn2
A7	Dn1	B6	Dp2
A8	SBU1	B5	CC2
A9	Vbus	B4	Vbus
A10	SSRXn2	B3	SSTXn2
A11	SSRXp2	B2	SSTXp2
A12	GND	B1	GND

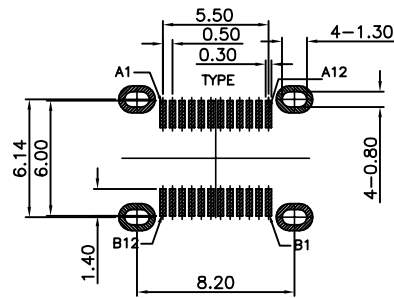
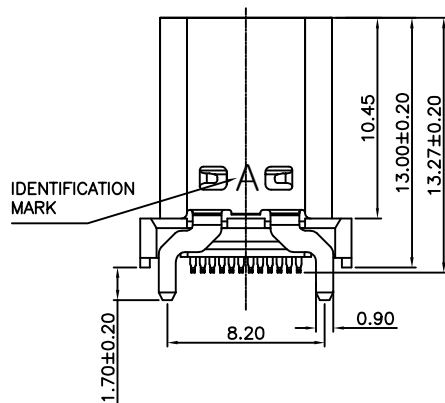

RECOMMEND P.C.B LAYOUT (COMPONENT SIDE)
TOLERANCE FOR PCB LAYOUT IS ± 0.05
KEEP OUT AREA

Item	Title	Material	Dispose	Q'TY
1	Shell	SUS304	Ni:30u" Min.	1PCS
2	GND Plate	SUS301		2PCS
3	Mid Plate	SUS301		1PCS
4	Contact	C7025	Mating Area: See P/N Solder Tails: Matt Tin	2PCS
5	Insert Molding	LCP E6808	UL 94V-0 Black	1PCS
6	COVER	LCP E6808	UL 94V-0 Black	1PCS

PART NO.: SEE THE PART NUMBER CODE		XNT-TYPE24P-LS0015		DRAWN BY SAM	DATE 2021-02-02
GENERAL TOLERANCES (UNLESS SPECIFIED)		TITLE USB 3.1 TYPE C F 直立式 H13.0 SMT TYPE (GND和EMI不短路款) 配大盖子外壳带字母		CHECKED BY JAY	DATE 2021-02-02
QUALITY SYMBOL	x.xxxxx	DWG.NO.	CF251-24-C3	APPROVED BY JACKY	DATE 2021-02-02
0	x.xxx	DIMENSION STYLE	MM ONLY	THIRD ANGLE PROJECTION	
0	x.xx	DESIGN UNITS	METRIC	SCALE 1:1	
0	x.x	SCALE	1:1	frame size: A4	
0	ANGULAR				